

**OPERATOR'S
SPARE PARTS &
SERVICE MANUAL**



®

**Hydraulic Power pack
Models FP6/6 (Honda)
FP6/20 (Honda)**

European Models

FAIRPORT

CONSTRUCTION EQUIPMENT LTD

Blagden Street
Sheffield
S2 5QS
ENGLAND
Tel: +44 (0) 114 276 7921
Fax: +44 (0) 114 272 0965
Email: sales@fairport.uk.com
Website: www.fairport.uk.com

Unit 32
The Bell Centre
Newton Road
Manor Royal
Crawley
West Sussex
RH10 9FZ
Tell +44 (0) 1293 534742
Fax +44 (0) 1293 529056

CONTENTS

1. INTRODUCTION	3
2. TECHNICAL DATA	3
3. HYDRAULIC OILS	3
4. SAFETY PICTOGRAMS USED ON THIS EQUIPMENT	4
5. SAFETY	4
6. OPERATION	5
7. FAULT DIAGNOSIS	6
8. ROUTINE SERVICING	7
8.1 Engine:	7
8.2 Powerpack:	7
9. MAINTENANCE, DISMANTLING AND REASSEMBLY	8
9.1 General	8
9.2 Hydraulic Pipes and Hoses	9
9.3 Self Locking Nuts	9
9.4 Thread Locking Compound	9
9.5 Draining the Hydraulic Oil	9
9.6 Dismantling and Reassembly	9
10. FLOW AND PRESSURE RELIEF VALVE ADJUSTMENT	10
11. POWER PACK ASSEMBLY 94044 Falcon 6/20	11
12. POWER PACK ASSEMBLY 94025 Falcon 6/6	13
13. MANIFOLD ASSEMBLY 94116	16
14. RELIEF VALVE ASSEMBLY	18
15. DRIVE ASSEMBLY FB 6/20 94118 (Before June 02)	19
16. DRIVE ASSEMBLY FB 6/6 94124 (Before June 02)	21
17. DRIVE ASSEMBLY FB 6/20 94060 (After June 02)	23
18. DRIVE ASSEMBLY FB 6/6 94125 (After June 02)	24
19. WARRANTY CONDITIONS AND CLAIMS PROCEDURE	26
CONDITIONS	26
CLAIMS PROCEDURE	27
20. REPAIRS AND ESTIMATES	27

1. INTRODUCTION

This manual provides information on the safe operation, servicing and repair of the following models of Fairport petrol engine hydraulic power packs:

FP6/6
FP6/20

The first number denotes the horsepower of the engine fitted to the power pack and the second number denotes the flow in litres per minute.

2. TECHNICAL DATA

	FP6/6	FP6/20
Eng. make	Honda	Honda
Eng. model	GX200	GX200
Fuel	Petrol	Petrol
Flow, l/min	6	20
at approx. eng. speed, rpm	3400	3400
Pressure, bar	98	98
Weight, kg	65	65
Length, mm	690	690
Width, mm	520	520
Height, mm	610	610
Guaranteed Sound power, dB(A)		104 Lwa
EHTMA category		

3. HYDRAULIC OILS

A wide range of compatible hydraulic oils is available. Ensure the product purchased is of good quality from a reliable source. Products from dubious sources must be avoided as they could adversely affect the reliability and operating efficiency of the hydraulic power pack and tool. The grade of hydraulic oil used will depend on ambient temperature as follows:

- Below 0°C use grade ISO 22 hydraulic oil.
- Between 0°C and 30°C use grade ISO 32 hydraulic oil.
- Above 30°C use grade ISO 46 hydraulic oil.

The capacity of the oil tank including priming the pump and pack hoses is 2.5 litres.

4. SAFETY PICTOGRAMS USED ON THIS EQUIPMENT



Read the manual before operating or servicing this equipment.

5. SAFETY

Read the safety instructions in the manual supplied with the equipment that this power pack is driving.

Read these operating and safety instructions before using the machine and operate the machine in accordance with these instructions.

Do not run engine in confined space.

Do not run engine unless all guards are in position.

Do not carry out any maintenance whilst engine is running.

Disconnect spark plug on petrol engines before carrying out any maintenance.

Do not fill fuel tank with engine running.

Wipe up spilt fuel. Dispose fuel contaminated wipes safely

Do not smoke while refuelling.

Do not run engine in areas that have a hazardous or explosive atmosphere.

Turn fuel tap off when not in use.

This machine must not be modified in any way without written permission of the manufacturer. Unauthorised modifications are likely to invalidate the warranty and also result in the machine not conforming to safety regulations.

Always comply with site safety regulations.

Inspect the machine for damage or improper function

To prevent accidental starting of the machine the spark plug lead must be removed before any maintenance or adjustments are carried out on the machine.

Do not attempt to fill fuel tank or oil sump while the machine is running.

When operating machines in confined areas, the exhaust fumes must be ventilated. Do not operate in an explosive atmosphere.

Understand and obey the safety labels and instructions attached to the equipment.

Do not attempt to operate defective equipment. Check that hoses and fittings are in good condition.

Ensure maintenance procedures are carried out as specified.

Do not attempt to operate this equipment on a greater hydraulic flow than that specified.

Fine jets of hydraulic oil can penetrate the skin. Check for leaks by holding a piece of cardboard near to the suspect area. If hydraulic oil does penetrate the skin or is ingested seek medical help immediately.

Always isolate hydraulic supply before making a disconnection or connection.

Always comply with local and site safety regulations.

6. OPERATION

Ensure the power pack is positioned safely.

Check the hydraulic oil in the power pack is suitable for the ambient temperature. See section on recommended hydraulic oils.

Check hoses and machine for damage.

Check hydraulic level.

Check operation and cleanliness of couplings.

Check that any hydraulic tools to be used are compatible with the flow and pressure available from the power pack. Do not use hydraulic tools if they require a lower flow than that provided by the power pack, the resulting over speed could be extremely dangerous.

Check oil level in the engine and that the grade of oil being used is as recommended for the ambient temperature according to the engine manufacturers' handbook.

Check the condition of the couplings both for cleanliness and damage.

Connect the hose couplings to the power pack couplings male to female.

Start the engine in accordance with the manufacturers' handbook.

Allow the engine to warm up for 3 to 4 minutes.

Move the flow control handle on the power pack from the 'off' position to the 'on' position.

Note that if the hoses and/or the tool are new or have been emptied of oil prior to use, the level of hydraulic oil in the tank will drop and may need topping up.

The tool may now be operated using the controls on the tool.
Never disconnect couplings with the flow control handle in the on position as the hoses will remain pressurised and it will be impossible to reconnect. If this does happen inadvertently the only way of releasing the pressure is to unscrew a coupling from the hose.

To shut down, first move the flow control lever to the 'off' position and then turn the engine switch to the off (0) position. After the engine has stopped turn the fuel tap to the off position.

When disconnecting couplings pull back the outside sleeve. Some couplings may require the sleeve to be rotated into its unlocked position before it can be slid back.

7. FAULT DIAGNOSIS

- ENGINE TURNS OVER BUT WILL NOT START

Check: ignition switch is on (position 1)
fuel tap is on
there is fuel in tank
engine oil level is correct
the choke is in correct position (closed if engine is cold, open if engine is hot).

If engine still does not start refer to engine manufacturer's handbook.

- ENGINE IS DIFFICULT TO TURNOVER

Check that the flow control lever is in the 'off' position.

If the engine will not turn over refer to the engine manufacturer's handbook.

- LOSS OF HYDRAULIC OIL

Check for damaged hoses, loose connections faulty couplings.

- **POOR TOOL PERFORMANCE**

Check that the power on demand cylinder is working.

Check for low pressure relief valve setting. This unit is pre-set at the factory and should require no further attention unless it has been tampered with. Reset as instructed in section 10.

Check that the suction strainer is not blocked.

Check that the hoses are not blocked.

Check for correct flow with a flow/pressure test unit and adjust engine speed and throttle setting as required as instructed in section 10. If engine speed needs to be set higher than 3600 rpm to achieve the required flow this indicates that the pump and/or diverter valve may be worn.

Tool fault – check tool handbook.

- **FOAMING OR MILK COLOURED HYDRAULIC OIL**

Air or water in the oil. Check filler cap is tight.

If associated with poor breaker performance the breaker accumulator may have degassed.

- **TOOL RUNNING HOT**

Check that the power pack has good access to cooling air.

Check that the oil cooler matrix is not blocked with debris.

Excess back pressure, check hoses for blockage.

Check cooling fan is not damaged.

Tool fault – check tool handbook.

- **ENGINE STOPS SUDDENLY**

Check fuel level in tank.

Check oil level.

8. ROUTINE SERVICING

8.1 Engine:

Refer to engine manufacturer's handbook.

8.2 Power pack:

Before Starting:

Check engine oil level.

Check hydraulic oil level.

At End of Shift:

Clean the machine using water and/or steam. Ensure water does not enter breather on hydraulic oil tank. Check that the air cooler matrix is clear of debris.

Check for oil leaks.

Every 1000 Hours or 6 Months

Change hydraulic oil.

Change suction strainer.

Change filter.

Check flow and pressure output.

9. MAINTENANCE, DISMANTLING AND REASSEMBLY

9.1 General

Parts are machined to a very high degree of accuracy and finish. On certain items the degree of accuracy of fit necessitates selecting parts to make up a matched assembly and may only be available as matched sets.

To ensure continued reliability, servicing should only be carried out by a skilled fitter who is experienced in working on hydraulics components.

The following general precautions must be observed when servicing hydraulic equipment:

- Absolute cleanliness is essential. Most hydraulic failures are caused by the ingress of dirt
- Before dismantling a component, clean external surfaces and drain all fluid.
- When holding components in a vice, fit soft metal pads over the vice jaws to prevent damage and distortion to precision surfaces and bores.
- All parts should be laid out on a clean resilient surface. Special attention should be paid to the identification of parts and their dismantling sequence.
- All dismantled metal parts should be washed in a cleaning solvent and coated with hydraulic fluid.
- The safety management of the company where the work is being carried out must approve all solvent cleaners in use. The COSHH regulations must be read and understood.

- It is recommended that all disturbed seals be renewed. If a seal is reused it should be closely examined for cuts, flaws or wear. A seal that is suspect should never be reused.
- All internal metal parts and seals should be lightly coated with clean hydraulic oil or a lithium based no.2 grade grease before assembly. This assists in assembly and lessens the risk of seal damage. Use only seals provided in component service kits, which are obtainable from Fairport Construction Equipment Ltd or their agents, as these will be of a different composition and hardness to seals normally commercially available.

9.2 Hydraulic Pipes and Hoses

When removing and replacing rigid pipes and flexible hoses the following points should be observed:

- Use adjustable or open-ended spanners on end connections and fittings. Do not use pipe wrenches as these damage fittings and protective plating.
- Ensure the particular connection and its surrounding area is clean.

9.3 Self Locking Nuts

These must not be reused.

9.4 Thread Locking Compound

Use the grade of compound recommended. Clean and degrease the joint or threads before application.

9.5 Draining the Hydraulic Oil

The old oil may be drained from the tank by disconnecting the suction hose. Do not reuse old hydraulic oil. Disposal of hydraulic oil should be carried out according to appropriate COSHH regulations. Do not pour it down the drain.

9.6 Dismantling and Reassembly

Dismantling and reassembly are straightforward by reference to the parts diagrams and parts lists.

10. FLOW AND PRESSURE RELIEF VALVE ADJUSTMENT

Fairport power packs are all pre-set for correct flow and pressure prior to despatch. If it is necessary to re-set flow or pressure an accurate in-line test unit is required such as those supplied by UCC International Ltd of Thetford, GB or Webster Instruments of St Ives, Cambridgeshire, GB. Proceed as follows:

1. Using a pair of hoses, connect the test meter so that the flow passes from the power pack, through the test meter and back to the power pack.
2. Start the engine and open the diverter valve.
3. Adjust the pressure-loading valve to give a pressure reading of about 55 bars to 60 bars. Allow oil to warm up on this setting for about 5 minutes.
4. Screw in the pressure-loading valve to give a pressure reading of 70 bars to 80 bars. The flow rate should read 20 or 6 litres per minute. If the flow rate is incorrect go to next paragraph. If flow rate is correct go to paragraph 6.
5. Check the relief valve setting by screwing in the pressure-loading valve until the pressure reading is 98 bar. At this reading the flow should be starting to fall off as the pressure relief valve is beginning to open. If this is not happening the relief valve will need adjusting. Slacken off the lock nut and unscrew the adjusting screw until the flow just starts to drop off. Retighten the lock nut. If on screwing the pressure-loading valve in it is not possible to achieve a pressure of 98 bars it may be that the relief valve has opened prematurely. In this case, with the pressure-loading valve screwed right in, slacken off the lock nut on the relief valve, screw in the adjusting screw until the pressure reading is 98 bars and retighten the lock nut. Slacken off the pressure-loading valve to give a reading of 98 bars and check the flow rate. Carry out further adjustments as required.
6. Whilst carrying out these checks ensure the oil temperature does not exceed 55°C.
7. Carry out a functional test by operating a tool, preferably a breaker, and checking for satisfactory operation.

11. POWER PACK ASSEMBLY 94044 Falcon 6/20

Item Number	Part Number	Title	Quantity
1	P70164	COOLER GUARD	1
2	P0967-00	OIL COOLER	1
3	W81918	HONDA GX200 ENGINE	1
4	435/8/40	HEX BOLT M8 x 40	8
5	418/8	M8 WASHER	8
6	480/8	M8 NYLOC NUT	4
7	P0079-00	WHEEL	2
8	P0966-00	CHASSIS	1
9	P1046-00	HOSE PUMP TO VALVE	1
10	P0937-00	GASKET	1
11	P0960-00	COWL	1
12	P70279	M6 LUG NUT	4
13	P0979-00	COOLER RETURN PIPE	1
14	P0206-00	FOOT	2
15	455/8/35	M8 x 35 SKT CAP SCR	4
16	P0970-00	SIGHT GAUGE	1
17	406/5/32	BOLT 5/16 UNF x 2"	4
18	94060	FALCON 6/20 DRIVE	1
19	P70271	FRAME ASSY	1
20	94116	MANIFOLD ASSY	1
21	P1133-00	SPRING	1
22	500/6/12	M6 x 12 BUTTON HD CAP SCR	20
23	P0259-00	FILLER BREATHER	1
24	P0969-00	SUCTION STRAINER	1
25	420/6	M6 WASHER	8
26	P70187	SPACER	1
27	P0087-00	GROMMET	1
28	526/8	M8 x 25 x 15 WASHER	4
29*	480/6	M6 NYLOC NUT	8
30	P1212-00	FRAME PLUNGER	1
31	P70012	HOSE COOLER RETURN	1
32	P84014	3/8 DOWTY	2

		WASHER	
33*	P84012	NIPPLE 3/8 BSP M/M	1
34	P84033	NIPPLE 3/8-1/2 BSP M/M	1
35	P70020	HOSE SUCTION	1
36	P0306-00	HAND GRIP	2
37*	P80262	WORM DRIVE CLIP	2
38	94030	6 M SIAMESE HOSE ASSY	1
39	P80565	ROUND INSERT	2

Not illustrated *

12. POWER PACK ASSEMBLY 94025 Falcon 6/6

Item Number	Part Number	Description	Quantity
1	P70164	COOLER GUARD	1
2	P0967-00	OIL COOLER	1
3	W81918	HONDA GX200 ENGINE	1
4	435/8/40	HEX BOLT M8 x 40	8
5	418/8	M8 WASHER	8
6	480/8	M8 NYLOC NUT	4
7	P0079-00	WHEEL	2
8	P0966-00	CHASSIS	1
9	P1046-00	HOSE PUMP TO VALVE	1
10	P0937-00	GASKET	1
11	P0960-00	COWL	1
12	P70279	M6 LUG NUT	4
13	P0979-00	COOLER RETURN PIPE	1
14	P0206-00	FOOT	2
15	455/8/35	M8 x 35 SKT CAP SCR	4
16	P0970-00	SIGHT GAUGE	1
17	406/5/32	BOLT 5/16 UNF x 2"	4
18	94125	FALCON 6/6 DRIVE	1
19	P70271	FRAME ASSY	1
20	94116	MANIFOLD ASSY	1
21	P1133-00	SPRING	1
22	500/6/12	M6 x 12 BUTTON HD CAP SCR	20
23	P0259-00	FILLER BREATHER	1
24	P0969-00	SUCTION STRAINER	1
25	420/6	M6 WASHER	8
26	P70187	SPACER	1
27	P0087-00	GROMMET	1
28	526/8	M8 x 25 x 15 WASHER	4
29*	480/6	M6 NYLOC NUT	8
30	P1212-00	FRAME PLUNGER	1
31	P70012	HOSE COOLER	1

		RETURN	
32	P84014	3/8 DOWTY WASHER	2
33*	P84012	NIPPLE 3/8 BSP M/M	1
34	P84033	NIPPE 3/8-1/2 BSP M/M	1
35	P70020	HOSE SUCTION	1
36	P0306-00	HAND GRIP	2
37*	P80262	WORM DRIVE CLIP	2
38	94030	6 M SIAMESE HOSE ASSY	1
39	P80565	ROUND INSERT	2

Not illustrated *

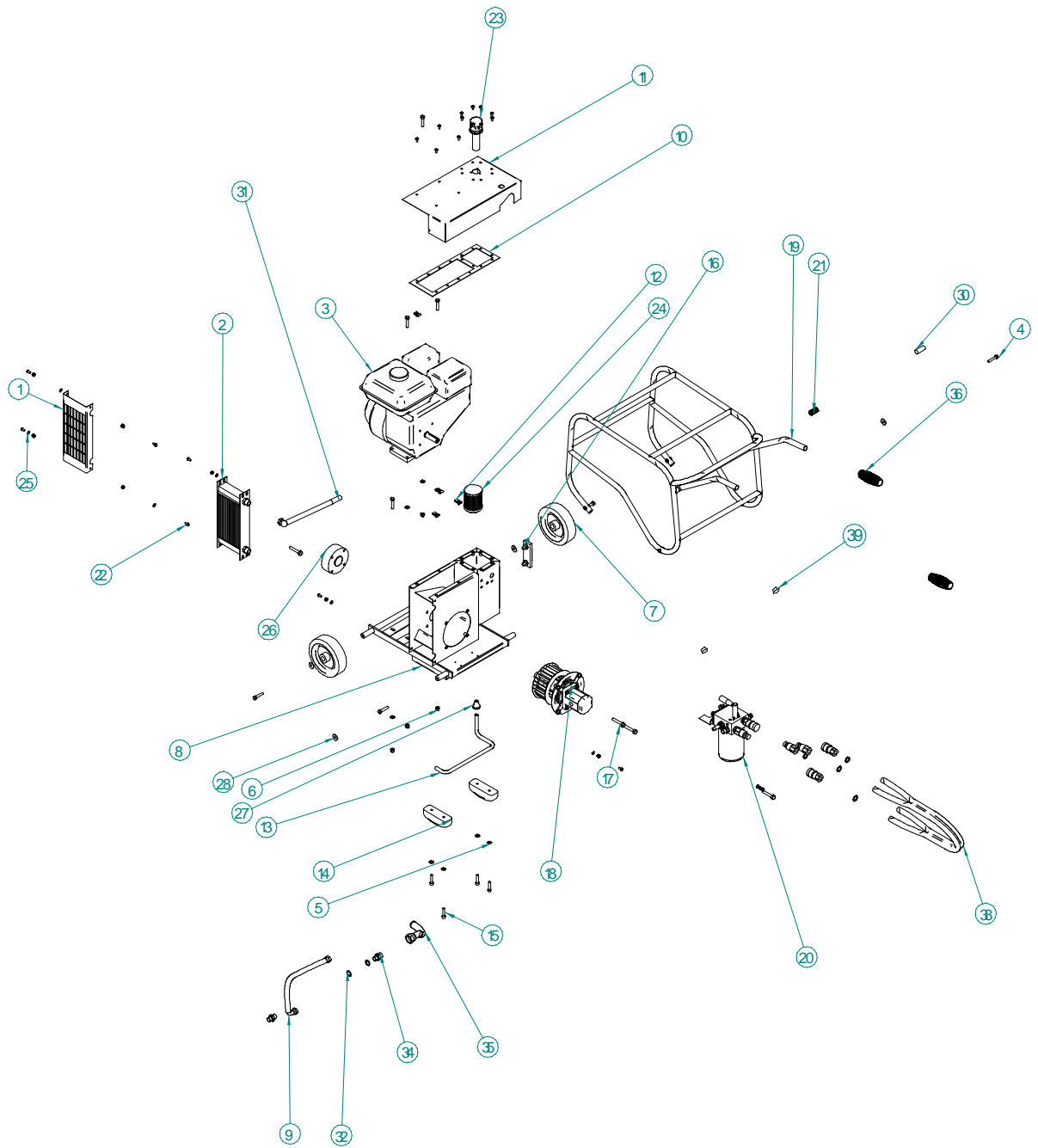

13. MANIFOLD ASSEMBLY 94116

Item Number	Part Number	Description	Quantity
1	440/8	M8 FULL NUT	3
2	P70231	TANK BAFFLE	1
3	P0913-00	CLAMP PLATE	1
4	94057	BY PASS VALVE ASSEMBLY	1
5	P0936-00	MANIFOLD GASKET	1
6	P1012-00	3/8 BSP HOSE TAIL	1
7	W88065	8MM NYLON TUBE	1
8	P122-3008-01	M8 x 30 SKT SCR	3
9	W88066	¼ BSP SWIVEL x 8MM ELBOW	1
10	P82050	O RING	1
11	P84012	NIPPLE 3/8 BSP M/M	3
12	P84014	3/8 DOWTY WASHER	6
13	P0911-00	MANIFOLD BLOCK	1
14	P0075-00	FILTER	1
15	P83968	HANDLE	1
16	P0263-00	FILTER SPIGOT	1
17	P013-1604-00	ROLL PIN	3
18	P80042	1/8 BSPT PLUG	4
19	P0172-00	RELIEF VALVE	1
20	P84051	QUICK RELEASE COUPLING	1
21	P84050	QUICK RELEASE COUPLING	1
22	417/8	M8 SHAKEPROOF WASHER	3
23	P0912-00	SPOOL	1
24	455/5/10	M5 x 10 SKT HD CAP	1
25	P83073	O RING	1

MANIFOLD ASSEMBLY

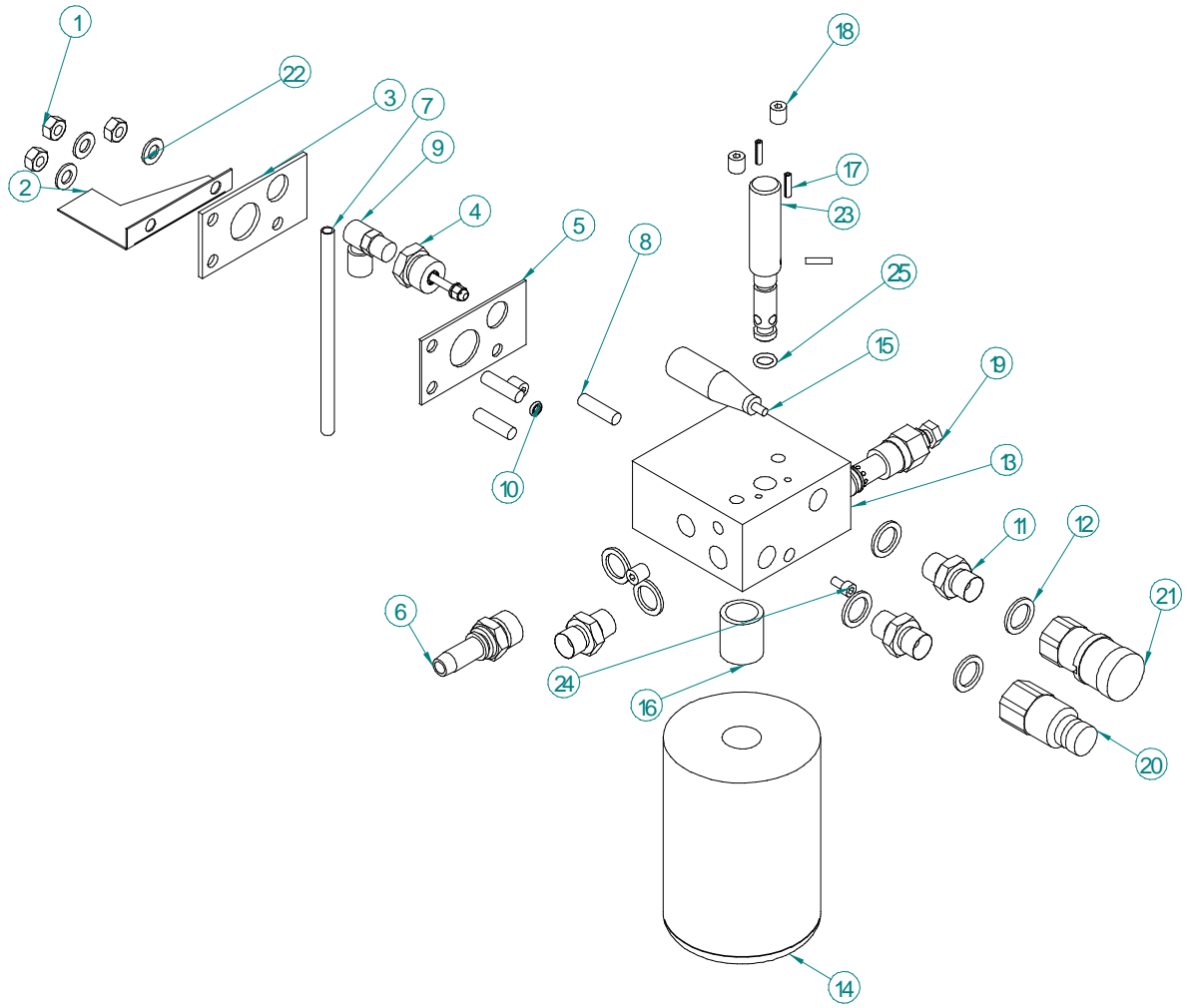

14. RELIEF VALVE ASSEMBLY

Item	Part No	Description	Qty
	94057	By-pass valve assy comprising:	
1	P70260	By-pass valve body	1
2	P469/5/30	M5 x 30 skt. csk. screw	1
3	P0549	Spring	1
4	420/5	M5 washer	1
5	480/5	M5 Nyloc nut	1

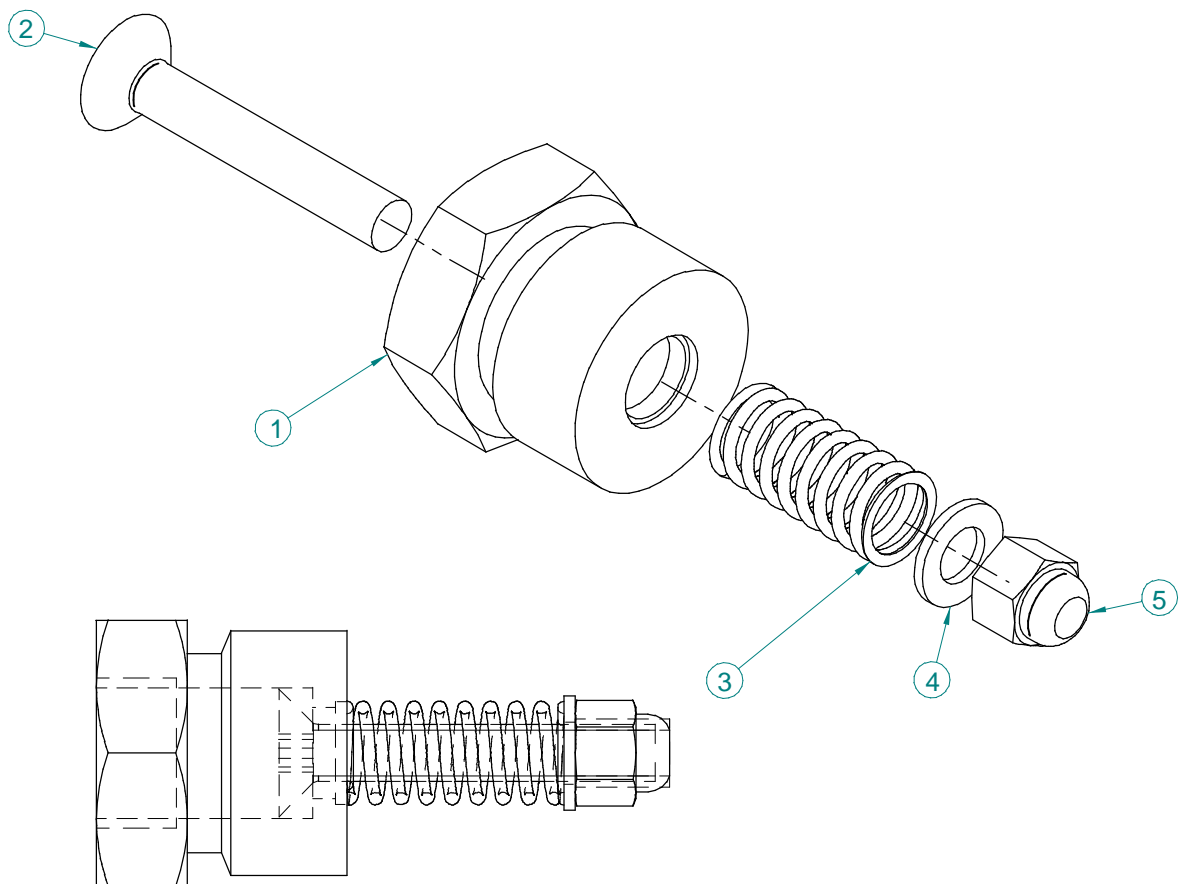

15. DRIVE ASSEMBLY FB 6/20 94118 (Before June 02)

Item Number	Part Number	Description	Quantity
1	P1011-00	FAN	1
2	P70189	TUBE	1
3	452/5/28	5/15 UNF x 1 ³ / ₄ CAP HD	1
4	P70196	MOTOR COUPLING	1
5	P1074-00	COUPLING SPIDER	1
6	P0948-00	FAN INLET RING	1
7	P70188	SHAFT	1
8	P70221	KEY	1
9	P1072-00	PUMP COUPLING	1
10	P0947-00	PUMP SPIDER	1
11	P1155-00	GROUP 1 PUMP	1
14	417/8	M8 SHAKEPROOF WASHER	4
15	455/8/20	M8 x 20 SKT HD CAP	4
16	420/6	M6 WASHER	4
17	455/6/30	M6 x 30 SKT HD CAP	4
18	480/6	M6 NYLOC NUT	4

16 DRIVE ASSEMBLY FB 6/6 94124 (Before June 02)

Item Number	Part Number	Description	Quantity
1	P1011-00	FAN	1
2	P70189	TUBE	1
3	452/5/28	5/15 UNF x 1 ¾ CAP HD	1
4	P70196	MOTOR COUPLING	1
5	P1074-00	COUPLING SPIDER	1
6	P0948-00	FAN INLET RING	1
7	P70188	SHAFT	1
8	P70221	KEY	1
9	P1072-00	PUMP COUPLING	1
10	P0947-00	PUMP SPIDER	1
11	P85157	GROUP 1 PUMP	1
14	417/8	M8 SHAKEPROOF WASHER	4
15	455/8/20	M8 x 20 SKT HD CAP	4
16	420/6	M6 WASHER	4
17	455/6/30	M6 x 30 SKT HD CAP	4
18	480/6	M6 NYLOC NUT	4

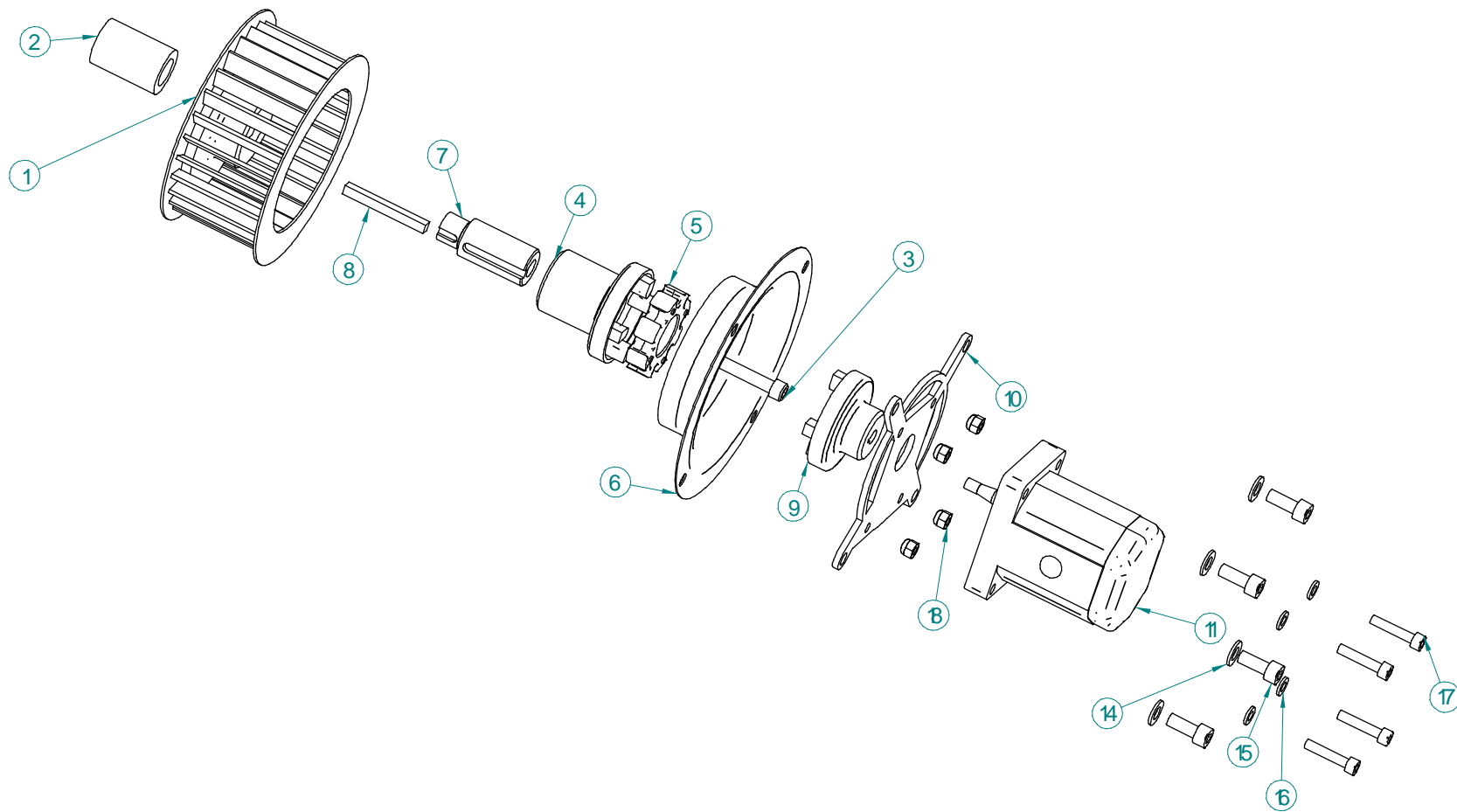

17 DRIVE ASSEMBLY FB 6/20 94060 (After June 02)

Item Number	Part Number	Description	Quantity
1	P70374	FAN	1
2	P70375	SHAFT ADAPTOR	1
3	P70373	SPACER	1
4	P70281	MOTOR COUPLING	1
5	P1074-00	COUPLING SPIDER	1
6	P0948-00	FAN INLET RING	1
7	P70372	TOP HAT	1
8*	452/5/52	5/16 UNF x 3 ¼ CAP HD	1
9	P1072-00	PUMP COUPLING	1
10	P0947-00	PUMP SPIDER	1
11	P1155-00	PUMP	1
12	P70376	KEY	1
13	P70377	KEY	1
14	417/8	M8 SHAKEPROOF WASHER	4
15	455/8/20	M8 x 20 SKT HD CAP	4
16	420/6	M6 WASHER	4
17	455/6/30	M6 x 30 SKT HD CAP	4
18	480/6	M6 NYLOC NUT	4

18. DRIVE ASSEMBLY FB 6/6 94125 (After June 02)

Item Number	Part Number	Description	Quantity
1	P70374	FAN	1
2	P70375	SHAFT ADAPTOR	1
3	P70373	SPACER	1
4	P70281	MOTOR COUPLING	1
5	P1074-00	COUPLING SPIDER	1
6	P0948-00	FAN INLET RING	1
7	P70372	TOP HAT	1
8*	452/5/52	5/16 UNF x 3 ¼ CAP HD	1
9	P1072-00	PUMP COUPLING	1
10	P0947-00	PUMP SPIDER	1
11	P1155-00	PUMP	1
12	P70376	KEY	1
13	P70377	KEY	1
14	417/8	M8 SHAKEPROOF WASHER	4
15	455/8/20	M8 x 20 SKT HD CAP	4
16	420/6	M6 WASHER	4
17	455/6/30	M6 x 30 SKT HD CAP	4
18	480/6	M6 NYLOC NUT	4

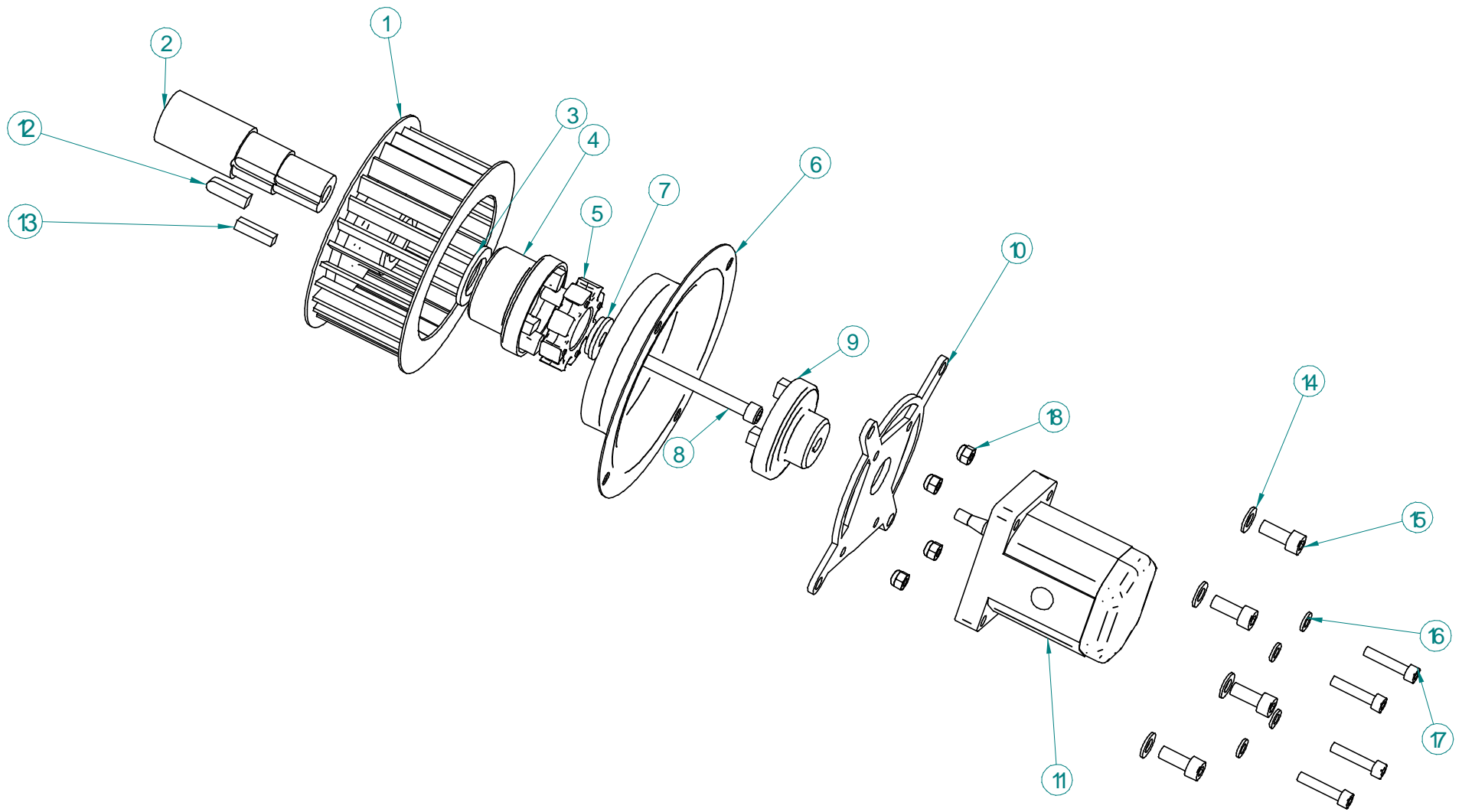

19. WARRANTY CONDITIONS AND CLAIMS PROCEDURE

All products supplied by Fairport Construction Equipment Ltd (hereafter referred to as FCE) are warranted to be free of defects due to faulty materials or workmanship for a period of 12 months from the date of original despatch from FCE or as specified below:

Hydraulic hoses and hydraulic couplings – 3 months.

Hydraulic accumulators – 6 months.

Flexible drives – 6 months.

All spare parts used in repairs carried out by FCE or an authorised dealer or repairer – 3 months.

If the goods have been purchased through a stockist the above warranty periods also apply from receipt of the goods by the user of the equipment up to a total of a further 6 months from date of despatch from FCE whichever is earlier.

Filter elements, gauges and oils are specifically excluded from this warranty.

FCE shall at their option repair or replace during normal working hour's goods accepted as faulty free of charge to the user.

For proprietary items such as engines, the original manufacturer's warranty and conditions shall apply.

CONDITIONS

The goods shall be returned at the purchaser's expense to FCE or to a destination FCE may reasonably direct. Carriage costs will be refunded if warranty is accepted.

Warranty claims will not be considered where there is evidence that failure has been caused by carelessness, improper use, negligence, inadequate servicing, incorrect engine speeds, fair wear and tear or non-compliance with instructions issued by the manufacturer.

To the extent permitted by law, the liability of FCE under this section is confined only to providing a remedy for defective goods and does not extend to any consequential loss, loss of profit, injury or damage suffered.

Warranty will not be accepted on dismantled goods unless dismantling was carried out with the written permission of FCE.

No claim shall be considered if other than genuine parts supplied by FCE have been used.

Products are only covered by this warranty in the country to where they were supplied by FCE.

Warranty on products applies only to the original user of the equipment.

This warranty shall not apply if the serial number or other identifying numbers or marks applied by FCE have been removed, defaced or are otherwise illegible.

CLAIMS PROCEDURE

Check that the goods are still under warranty before returning them to FCE (see above for warranty periods).

Return the goods to FCE with an order number for the work to proceed. If warranty is accepted no charge will be made. If warranty is not accepted a quotation will be given for the repair and the conditions under the section headed REPAIRS AND ESTIMATES will apply.

In the customer's interest, goods must be accompanied by documentation detailing the nature of the fault or its symptoms. Phrases such as 'Faulty' are unacceptable and will result in delays and possible charges to defray costs incurred in identifying the fault.

In the case of hydraulic breakers and power packs, both the breaker and the pack should be returned

20. REPAIRS AND ESTIMATES

When returning a machine, or an assembly for repair, always include an Advice Note quoting model and serial number of the machine.

An official order must also be forwarded to FCE giving detailed instructions. No repair work can be carried out unless covered by an official order.

An estimate will be submitted before proceeding with any repair. To partly cover the cost in dismantling, cleaning and inspection, a small charge will be made; this however will be waived upon receipt of your official instructions to proceed with the repair.

In the event of the estimate not being accepted, a further charge will be made to defray the rebuilding of the machine.

Estimates must be treated as approximate only as it may be found necessary to use additional parts on further examination.

EC Declaration of Conformity

We Fairport Construction Equipment Limited

Blagden Street

Sheffield

S2 5QS

Declare that the product

PP 193 Fitted with Honda GX160 engine

Manufactured from 1 Sept 2004

conforms to the following Directives:

89/336/EEC, 89/392/EEC, 91/368/EEC, 2000/14/EC

uses the following standards:

BS EN 292-1, BS EN 292-2, BS EN 294

conforms to the following Statutory Instruments

The Supply of Machinery (Safety) Regulations 1992 & amendments

Complies with the relevant essential health and safety requirements of the Machinery Directive

Technical Construction File no. **93044**

Noise Construction Technical File **FP6/20 2004**



Technical Manager

Signature	Position
R.J.Castle I.Eng M.I.Mech.E.	12/12/2005
Signed by	Date